

HOT FILL FORM SEAL MACHINE

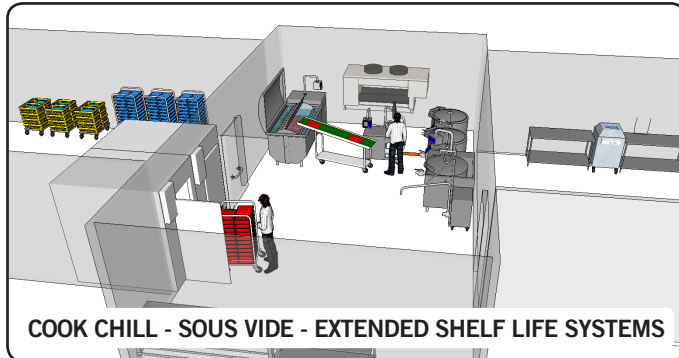

- The Regethermic Hot fill vertical form fill machine is designed for high speed bag filling direct from larger size vessels starting from 300 litres
- Casings are formed from a continuous flat form roll
- Once a program is set for a specific product simply let the machine do the rest
- The Vertical Form Filler is complimented when used in conjunction with conveyor belt
- Hot casings may be deposited directly into Regethermic Tumble Chiller to complete the process

Product information

- 20 x three (3) litres pillow bags per minute
- Food temperature 90 degrees Celsius
- Bag width from 100-210mm
- Volume up to four(4) litres
- Simple to operate
- Easy to clean
- PLC controlled
- Suitable for packaging - hot pumpable fluids with solids up to 15mm
- Sealing jaw constant heat with PID. digital temperature control
- Machine runs in index mode with constant heat crimp sealing bar
- Machine controlled by PLC and touch screen
- Full stainless steel and aluminium construction
- IP65 control box
- Belt drive design allows easy to change bag length
- Comes supplied as standard with an impact printer capability able to supply batch number and use by date only.



Over 40 years experience in specialised catering systems

HOT FILL FORM SEAL MACHINE

Regethermic Australia
 131 Alexander Street
 Crows Nest NSW 2065
 Ph +61 2 9966 9500

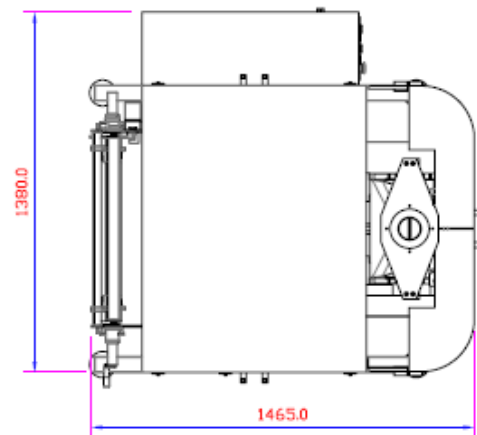
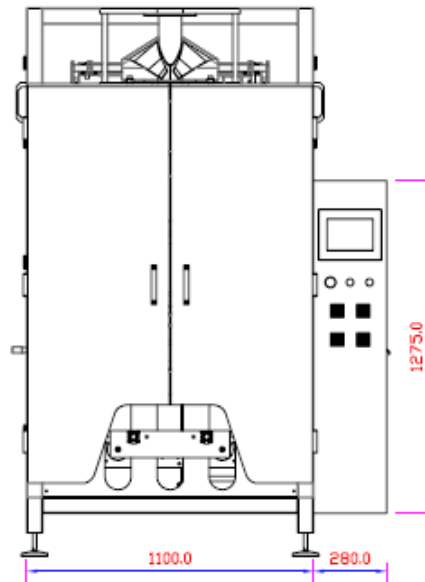
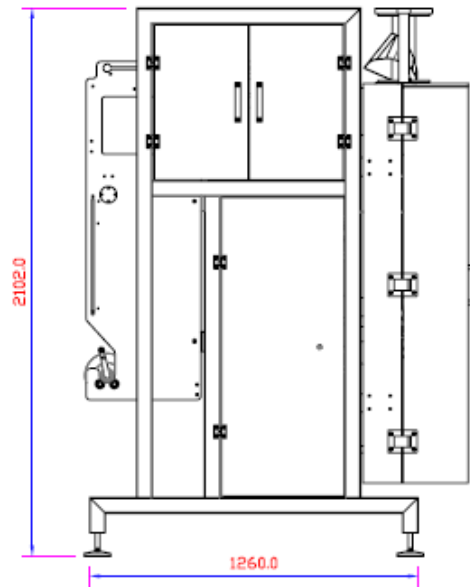

Specifications

Power option	415V, 3~, 10A (2kW)
Dimensions (LWH)	1465 x 1380 x 2102
Est weight	850 kg
Compressed Air	500 litres/min @ 6bar

Options & Accessories

In-line lobe pumps
Second former
Dishcharge conveyor
Printers

Over 40 years experience in specialised catering systems